

IRE-2.0 Dual IR Emitter

INSTALLATION INSTRUCTIONS



ELT03200

LIT03200 02/02

DESCRIPTION

The IRE-2.0 is the dual emitter version of the IRE-1.0. It features a unique EZ-Docker™ port that permits instant removal of the emitter when rearranging or servicing components. An improved adhesive reduces callbacks for reattachment of “fallen emitters”. The case may also be taken apart so that the tiny internal emitter can be placed inside a component, when desired. High IR output from the top curved surface allows emitter to be mounted on a nearby surface, below, above or on a cabinet door, rather than directly on the sensor of the unit where conditions permit.

Fig. 1

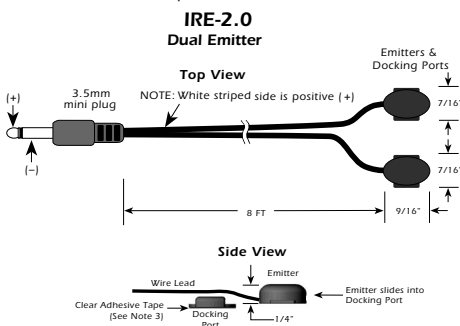

ATTACHMENT

First, locate the component's IR Sensor window (see Note 1) and thoroughly clean it of any fingerprints or other greasy substances. The EZ-Docker™ port has a clear adhesive layer on its bottom surface. Peel the protective layer off, exposing the adhesive.

Orient the port vertical (see Fig. 2) and press it over the center of the component's sensor window. Press & hold for several seconds to ensure maximum contact of the adhesive.

Insert the 3.5mm plug into an Emitter jack on a SpeakerCraft Terminator or other source of IR (see Fig. 3). Slide the emitter from the top down, into the EZ-Docker™ port.

IR Controlled Components

Fig. 2

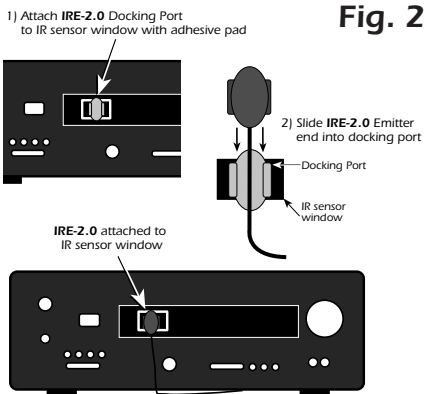

You should feel it “snap” into place. (To remove the emitter at any time, simply push upward until it “pops” out.)

Insert the 3.5mm plug into an Emitter jack on a SpeakerCraft Terminator or other source of IR (see Fig. 3).

CAUTION: Do not plug into an emitter jack that is set to Blaster Power (BL ON) or to the HIGH OUT of other connecting blocks. **To do so will smoke the emitters!!**

Note 1: If you have difficulty finding the component's IR sensor, try using a flashlight. Sometimes the owner's manual is helpful. You may need to contact the manufacturer direct.

Note 2: You may also attach the emitter without the EZ-Docker™ port. Use one of the spare adhesives (included) applying it directly to the bottom surface of the IRE-2.0 shell.

Note 3: If you need to remove the EZ-Docker™ port or emitter previously stuck to a component's surface, use a fresh adhesive (included) before reattaching.

TYPICAL INSTALLATION

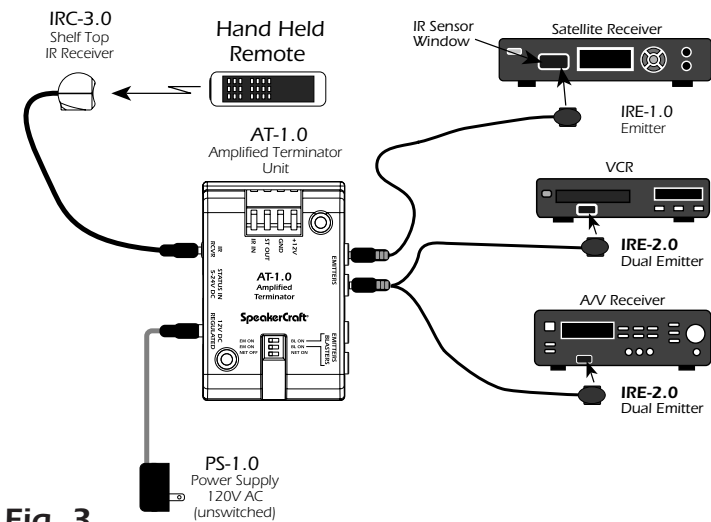

Fig. 3

Note 4: The emitters on the IRE-2.0 are wired in series. If you cut one off, you will need to short the cut-off wires together for the other one to operate.

Note 5: The emitter shell and EZ-Docker™ port, though dark in appearance, are transparent to Infrared. This allows IR commands to pass through them, permitting local hand held remote control as well as through the IRE-2.0.

Other Emitter Placements

Since the IRE-2.0 has high output from its curved top (See Fig. 4), you may attach it to other surfaces nearby, if the installation permits. (See Fig. 5)

Fig. 4

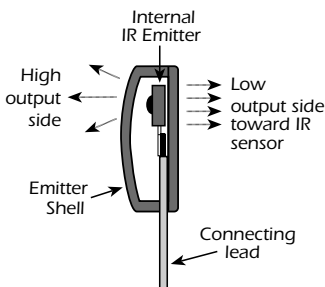

Use the higher power setting (NOT Blaster Power) on the connecting block or terminator, if so provided.

Some installers like the option of placing the emitter completely inside a component, as near as possible to the IR sensor, for a clean external appearance. In some cases, the whole emitter can be so placed.

IR Controlled Components

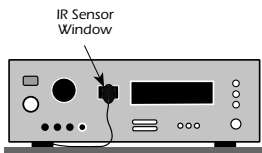

Fig. 5a IRE-2.0 attached directly to IR sensor window



Fig. 5b IRE-2.0 attached to inside of cabinet door directly opposite IR sensor window

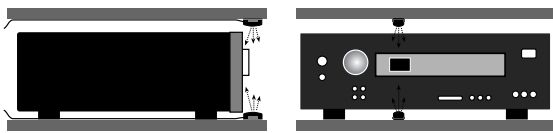

Fig. 5

Fig. 5c & d IRE-2.0 attached to shelf directly below or above IR sensor window

In others, it may be necessary to remove the internal emitter from its shell so that it will fit in tiny chassis places. In this case, use the thin edge of a knife to carefully pry the lower cover from the shell of the emitter. Gently ease the tiny emitter and lead from its nest within the shell. Use heat shrink tubing, or other insulating means, to prevent shorting of the exposed leads.

LIMITED 5-YEAR WARRANTY

SpeakerCraft warrants this product to be free of defects in materials or workmanship. This extends for five years from the date of purchase by the original consumer. Any products returned to SpeakerCraft and found to be defective by SpeakerCraft within the warranty period will be repaired or replaced, at SpeakerCraft's option, at no charge. SpeakerCraft will not be responsible for the actual cost of installation or removal of the product, nor for any incidental or consequential damages. Some states do not allow the exclusion or limitation of incidental or consequential damages, so the above limitation may not apply to you. This warranty gives you specific legal rights. You may have additional legal rights that vary from state to state.

SpeakerCraft®

SpeakerCraft • 1650 Seventh Street, Riverside, CA 92507 • Phone 1-800-448-0976 • Fax 888-599-9059

www.speakercraft.com